

SR-MI-A-250-## Backward Curved Motorized Impeller

Technical Specification*

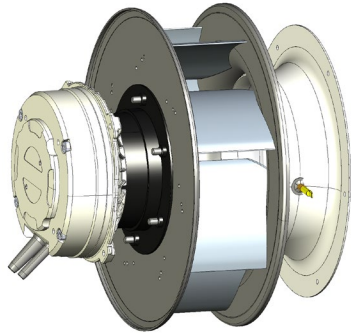

Application

- Various systems of mechanical ventilation,
- Primary Air Movement units for Air Handling Units, Roof Top Units and other,
- Ventilation systems requiring low Specific Fan Power (SFP) together with smooth and precise airflow adjustment,
- Perfect solution to be combined into Fan-Array systems,
- Fitted for Vertical and Horizontal Arrangement.

General Specification

- Motorized impeller with separate inlet funnel,
- Support to CAV/VAV systems (factory mounted static pressure probes on fan inlet vane + precisely determined K-factor),
- Air performance according to ISO 5801, Installation Category: A, L_wA according to ISO 13347.

Impeller

- Type: Radial, Backward-curved, Single Inlet,
- Material: High Performance Aluminum (A),
- Balance quality grade: G 6,3 (ISO 1940-1) and BV-3 (ANSI S2.19-1989)

Inlet funnel

- Material: Hot-dip galvanized steel.

Motor

- Type: Electronically Commutated, Spinning Stator,
- Housing: Die-cast aluminum,
- Protection Degree: IP54,
- Overload Protection: Inbuilt Thermal Limit,
- Speed Control: 0~10VDC / Modbus RTU,
- Bearing: Ball Type.

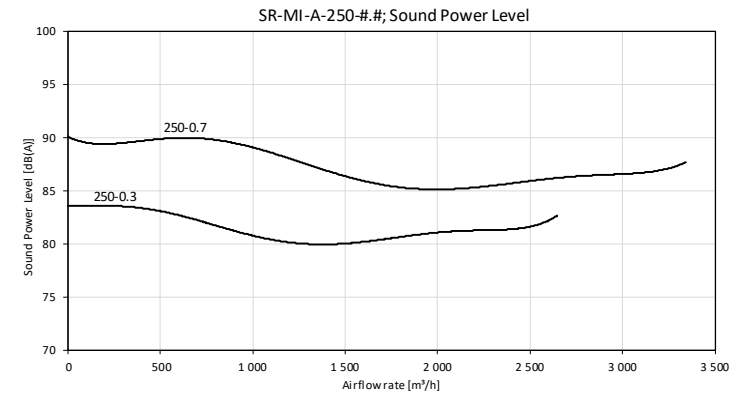
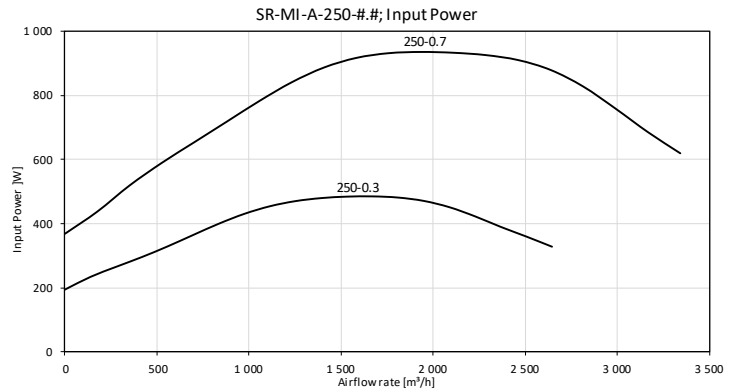
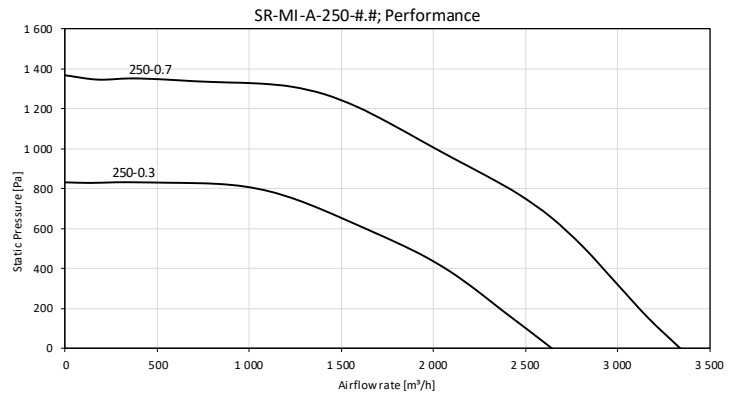

FanSet Model	Power supply			Revolutions [min ⁻¹]		Efficiency		Reference standards			CAV K-factor	Weight
	Rated Voltage	Rated Current	Input Power	Min	Max/Nominal	Static	FEG	ErP	CE	UL		
SR-MI-A-250-0.3	1x230 VAC / 50-60 Hz	3.3 A	0.5 kW	300	3 000	56%	85	2018	Yes	Yes	63.7	3.4 kg
SR-MI-A-250-0.7	1x230 VAC / 50-60 Hz	5.6 A	0.9 kW	380	3 800	60%	90	2018	Yes	Yes	64.0	5.4 kg

Model	A-250-0.3	A-250-0.7
A	133	153
B	114	150
C	240	240
D	285	285
E	229	255
F	196	207
G	115	112
H	152	162
I	125	164

