

Appearance

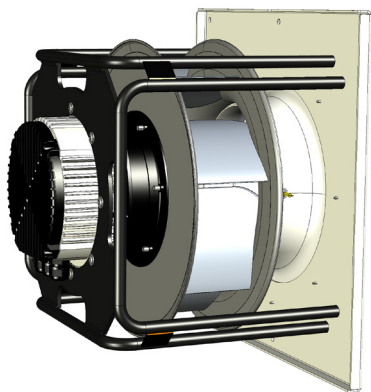

Application

Various mechanical ventilation systems, air handling units, rooftop units, and others

Ventilation systems requiring low Specific Fan Power (SFP) together with smooth and precise airflow adjustment

Perfect solution to be combined into Fan-Array systems

Fitted for vertical and horizontal arrangement

Support to CAV/VAV systems (factory mounted static pressure probes on fan inlet vane + precisely determined K-factor)

Air performance according to ISO 5801, Installation Category: A, LWA according to ISO 13347.

General specification

Fan Set Model	SR-FS-A-400-3.7
Rated Voltage	3×380-480 VAC / 50-60 Hz
Rated Current	5.0 A
Nominal Input Power	3.4 kW
Revolutions: Min / Nominal	300 ÷ 2800 RPM
CAV K-factor	163.0
Storage temperature range	-30°C to 50°C
Operating temperatures range	-25°C to 40°C
Support plate material	Galvanized steel
Support brackets material	Black painted steel
Mass	38.2 kg
Installation position	Horizontal / Vertical shaft

Motor

Type	Electronically Comutated, Brushless DC
Housing	Die-cast aluminum
Protection Degree	IP 54
Overload protection	Inbuilt thermal limit
Speed Control	0~10VDC / Modbus RTU
Bearings	Ball type

Impeller

Fan Impeller Size	400 mm
Blade design / No of blades	Aerofoil / 7
Spinning direction	Clockwise, wiewed from air inlet
Impeller material	Aluminum
Inlet funnel material	Hot-dip galvanized steel
Balance grade	G 6,3 (ISO 1940-1) and BV-3 (ANSI S2.19-1989)

Installation Dimensions

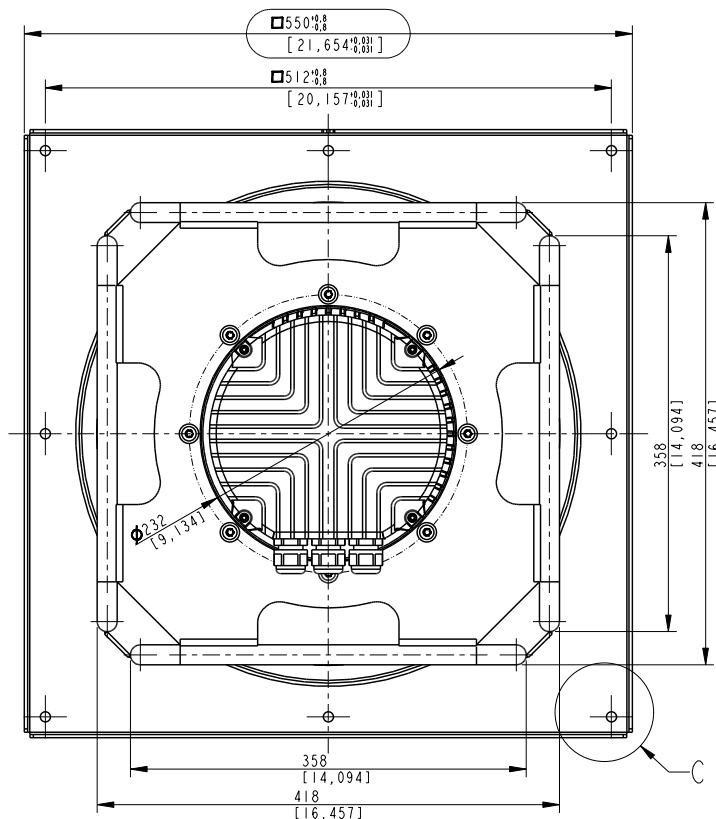
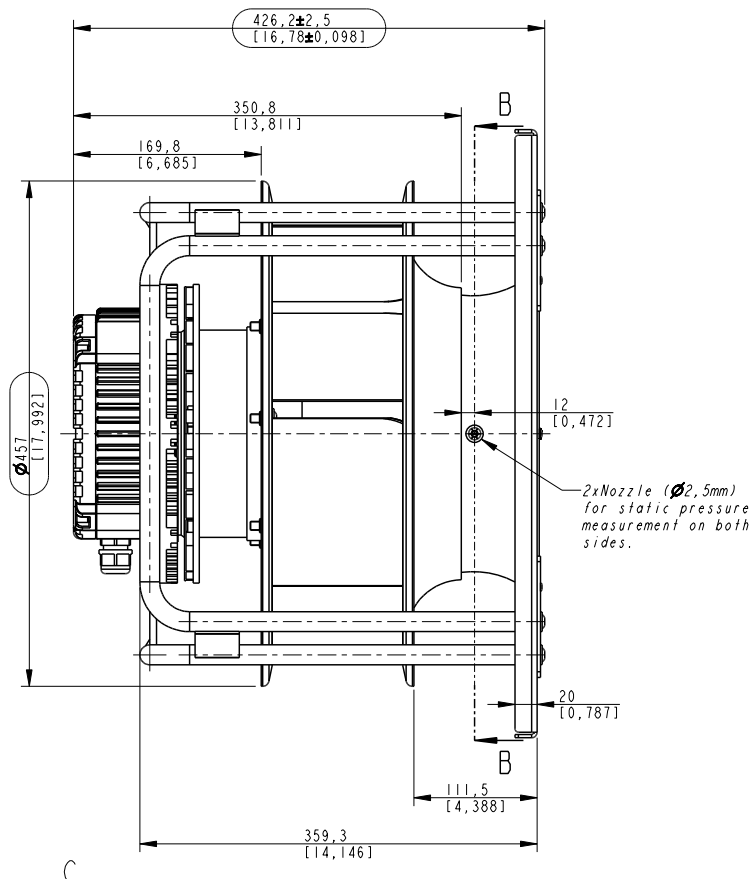

dP = f(V)

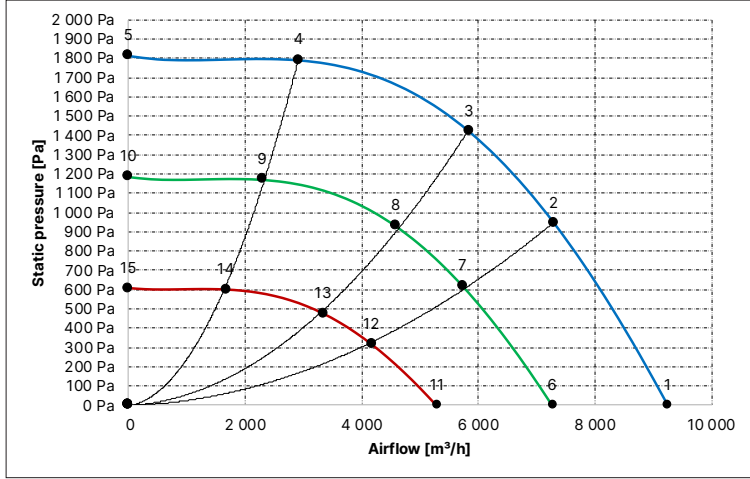

Measurment Points

Point #	n RPM	EPC [kW]	I[A]	L _p A _{in} dB(A)	L _w A _{in} dB(A)	L _w A _{out} dB(A)	V [m³/h]	dP [Pa]
1	2 800	2.34	3.1	86.9	94.9	97.6	9 244	0
2	2 800	3.39	4.5	81.1	89.1	93.2	7 298	944
3	2 800	3.63	4.8	78.1	86.1	91.4	5 839	1 421
4	2 800	2.91	3.8	81.9	89.9	94.5	2 919	1 791
5	2 800	1.36	0.0	82.8	90.8	96.6	0	1 814
6	2 200	0.71	1.6	79.6	87.6	90.3	7 263	0
7	2 200	1.76	2.3	74.0	82.0	86.1	5 734	618
8	2 200	1.89	2.5	71.5	79.5	84.4	4 587	930
9	2 200	1.51	2.0	74.8	82.8	86.8	2 294	1 172
10	2 200	0.71	0.9	75.7	83.7	89.0	0	1 187
11	1 600	0.50	0.7	72.2	80.2	83.0	5 282	0
12	1 600	0.72	1.0	66.9	74.9	78.9	4 170	315
13	1 600	0.77	1.0	64.8	72.8	77.4	3 336	474
14	1 600	0.62	0.8	67.8	75.8	79.0	1 668	598
15	1 600	0.29	0.4	68.7	76.7	81.3	0	605

EPC = f(V)

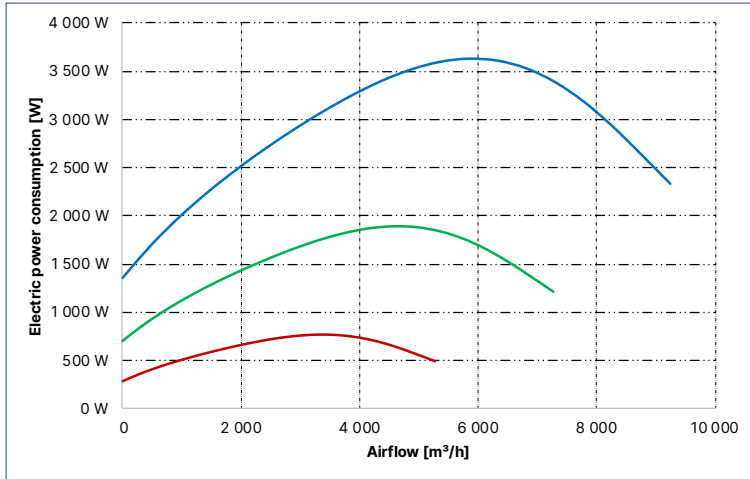

η_{st} = f(V)

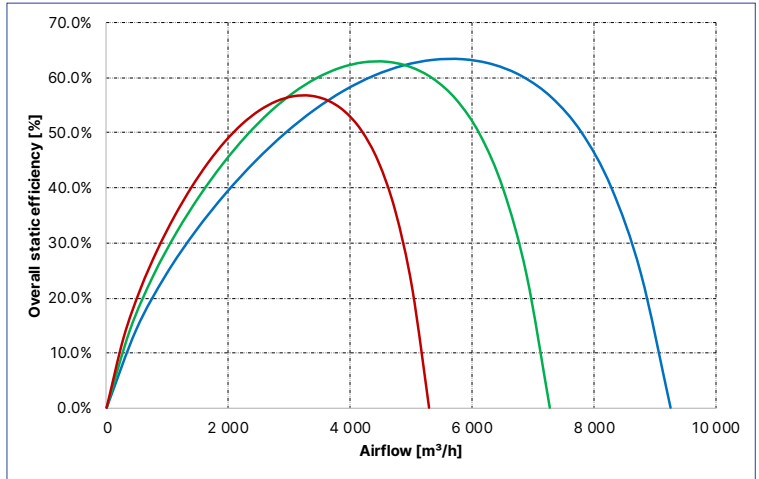

Compliance with Standards

ISO 5801:2017	„Fans – Performance testing using standardized airways”
Commission Regulation(EU) 327/2011	Requirements for fans driven by motors with an electric input power between 125 W and 500 kW.

Information according to (EU) 327/2011 (ERP 2018)

1	Overall efficiency η _{es}	66.7%
2	Measurement category	A
3	Efficiency Category	Static
4	Efficiency grade N: Actual / Req. 2015	67.9%
5	Variable speed drive	Yes
9	Power consumption P _{ed}	3.83 kW
	Air flow q _v	5 836 m³/h
	Pressure increase p _{fs}	1 499.2
10	Speed (rpm) n	2 850
11	Specific ratio	1.01

Connection of power and control cables

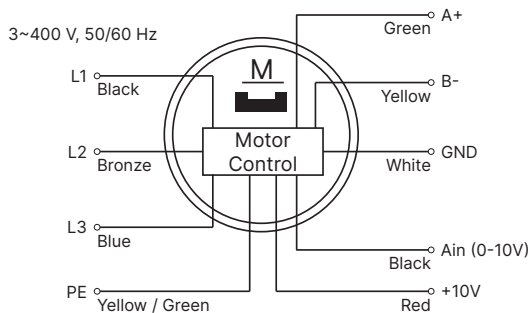

Wire Harness	Terminal Number / Color	Description
Power Supply	L1	Black
	L2	Brown
	L3	Blue
	PE	Yellow / Green
Control	A	Green
	B	Yellow
	10 V	Red
	Ain	Black
	Gnd	White