

Appearance

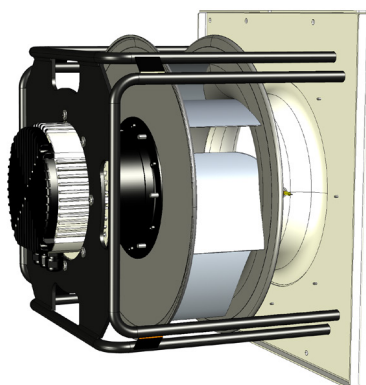

General specification

| | |
|------------------------------|-----------------------------|
| Fan Set Model | SR-FS-A-450-3.7 |
| Rated Voltage | 3×380-480 VAC / 50-60 Hz |
| Rated Current | 5.7 A |
| Nominal Input Power | 3.7 kW |
| Revolutions: Min / Nominal | 300 ÷ 2300 RPM |
| CAV K-factor | 205.0 |
| Storage temperature range | -30°C to 50°C |
| Operating temperatures range | -25°C to 40°C |
| Support plate material | Galvanized steel |
| Support brackets material | Black painted steel |
| Mass | 45.6 kg |
| Installation position | Horizontal / Vertical shaft |

Motor

| | |
|---------------------------------------|---|
| Type | Electronically Comutated, Brushless DC |
| Housing | Die-cast aluminum |
| Protection Degree | IP 54 |
| Overload protection | Inbuilt thermal limit |
| Speed Control | 0~10VDC / Modbus RTU |
| Bearings | Ball type, Maintenance Free, Permanently Lubricated |
| Bearings service life L ₁₀ | 71 200 (40 °C) / 35 600 (max. work. temperature) |

Application

Various mechanical ventilation systems, air handling units, rooftop units, and others

Ventilation systems requiring low Specific Fan Power (SFP) together with smooth and precise airflow adjustment

Perfect solution to be combined into Fan-Array systems

Fitted for vertical and horizontal arrangement

Support to CAV/VAV systems (factory mounted static pressure probes on fan inlet vane + precisely determined K-factor)

Air performance according to ISO 5801, Installation Category: A, LWA according to ISO 13347.

Impeller

| | |
|-----------------------------|---|
| Fan Impeller Size | 450 mm |
| Blade design / No of blades | Aerofoil / 7 |
| Spinning direction | Clockwise, wiewed from air inlet |
| Impeller material | Aluminum |
| Inlet funnel material | Hot-dip galvanized steel |
| Balance grade | G 6,3 (ISO 1940-1) and BV-3 (ANSI S2.19-1989) |

Installation Dimensions

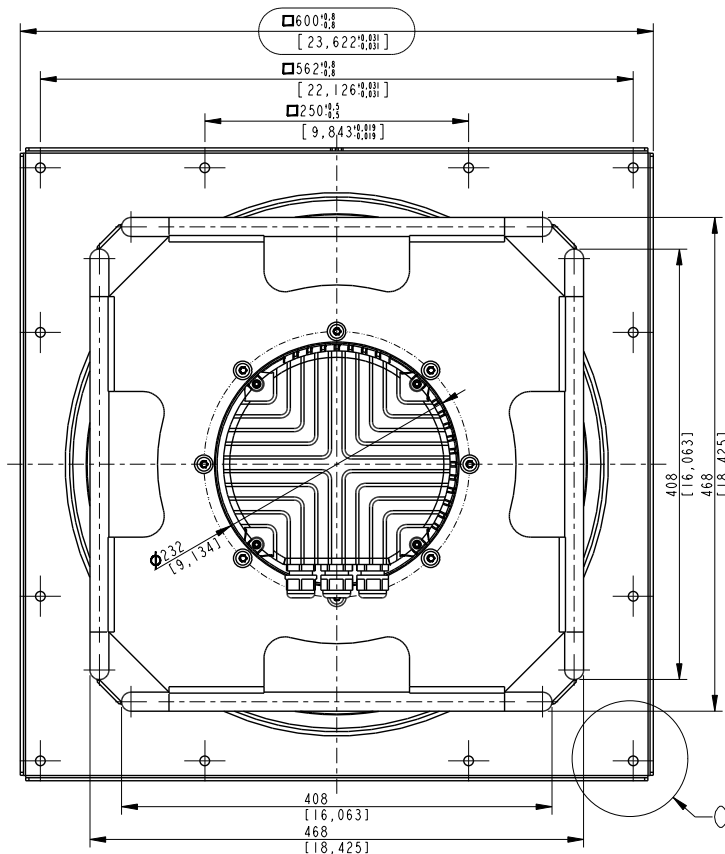
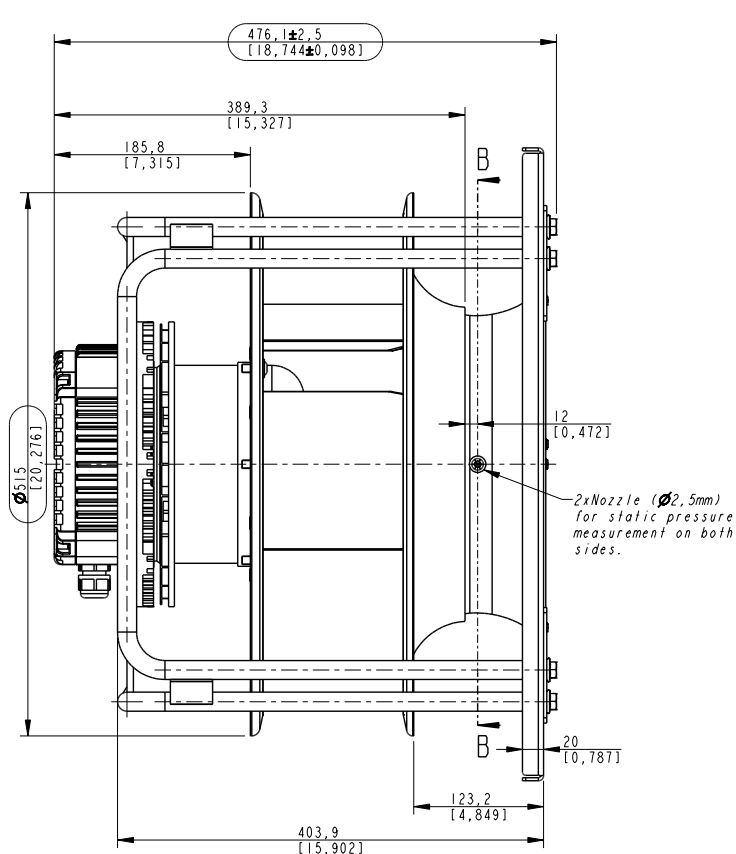

Gnd

Information according to (EU) 327/2011 (ERP 2018)

| | | |
|-------------------------------------|--|---|
| Commission Regulation (EU) 327/2011 | | Requirements for fans driven by motors with an electric input power between 125 W and 500 kW. |
| 1 | Overall efficiency η_{es} | 67.7% |
| 2 | Measurement category | A |
| 3 | Efficiency Category | Static |
| 4 | Efficiency grade N: Actual / Req. 2015 | 69.2% |
| 5 | Variable speed drive | Yes |
| 9 | Power consumption P_{ed} | 3.57 kW |
| | Air flow q_v | 7 086 m ³ /h |
| | Pressure increase pfs | 1 170.1 |
| 10 | Speed (rpm) n | 2 300 |
| 11 | Specific ratio | 1.01 |

Compliance with Standards

| | |
|---------------------------|---|
| ISO 5801:2017 | „Fans – Performance testing using standardized airways” |
| ANSI/AMCA Standard 210-16 | Laboratory Methods of Testing Fans for Certified Aerodynamic Performance Rating |
| ANSI/AMCA Standard 300-14 | Reverberant Room Method for Sound Testing of Fans |
| AMCA Standard 205-10 | Energy Efficiency Classification for Fans |
| ANSI/AMCA Standard 208-18 | Calculation of the Fan Energy Index |

AMCA Certification

Swiss Rotors Sp. z o.o. certifies that the

SR-FS-A-450-3.7 Fan Set

shown herein is licensed to bear the AMCA seal. The ratings shown are based on tests and procedures performed in accordance with AMCA Publication 211 and AMCA Publication 311 and comply with the requirements of the AMCA Certified Ratings Program.

Power rating does not include transmission losses.

Performance ratings do not include the effects of appurtenances.

Performance certified is for installation type A (Free inlet, free outlet).



AMCA Fan Efficiency Grade

| | |
|---|----|
| Fan Efficiency Grade (FEG), AMCA 205-10 | 80 |
|---|----|

Measured Points

| Point # | n [RPM] | V [m ³ /h] | dP [Pa] | I [A] | EPC [kW] | L _{pAin} [dB(A)] | L _{wAin} [dB(A)] | L _{wAout} [dB(A)] | FEI |
|---------|---------|-----------------------|---------|-------|----------|---------------------------|---------------------------|----------------------------|------|
| 1 | 2 300 | 9 985 | 443 | 4.3 | 3.00 | 87.1 | 95.1 | 95.9 | 0.97 |
| 2 | 2 300 | 8 811 | 792 | 4.8 | 3.38 | 82.1 | 90.1 | 92.6 | 1.27 |
| 3 | 2 300 | 7 048 | 1 169 | 5.1 | 3.58 | 77.2 | 85.2 | 89.6 | 1.39 |
| 4 | 2 300 | 3 524 | 1 521 | 4.2 | 2.92 | 79.6 | 87.6 | 92.8 | 1.13 |
| 5 | 2 300 | 1 762 | 1 561 | 3.3 | 2.25 | 81.0 | 89.0 | 94.8 | 0.82 |
| 6 | 1 649 | 7 159 | 231 | 1.9 | 1.18 | 79.9 | 87.9 | 88.6 | 1.07 |
| 7 | 1 649 | 6 317 | 413 | 2.1 | 1.33 | 74.9 | 82.9 | 85.4 | 1.31 |
| 8 | 1 649 | 5 053 | 610 | 2.2 | 1.41 | 69.9 | 77.9 | 82.4 | 1.40 |
| 9 | 1 649 | 2 527 | 794 | 1.9 | 1.15 | 72.4 | 80.4 | 85.6 | 1.15 |
| 10 | 1 649 | 1 263 | 815 | 1.6 | 0.89 | 73.8 | 81.8 | 87.6 | 0.87 |
| 11 | 1 000 | 4 341 | 85 | 0.8 | 0.32 | 69.1 | 77.1 | 77.8 | 1.36 |
| 12 | 1 000 | 3 831 | 152 | 0.9 | 0.36 | 64.0 | 72.0 | 74.5 | 1.47 |
| 13 | 1 000 | 3 065 | 224 | 0.9 | 0.38 | 59.1 | 67.1 | 71.5 | 1.47 |
| 14 | 1 000 | 1 532 | 291 | 0.8 | 0.31 | 61.5 | 69.5 | 74.7 | 1.22 |
| 15 | 1 000 | 766 | 299 | 0.7 | 0.24 | 62.9 | 70.9 | 76.7 | 0.98 |

dP = f(V)

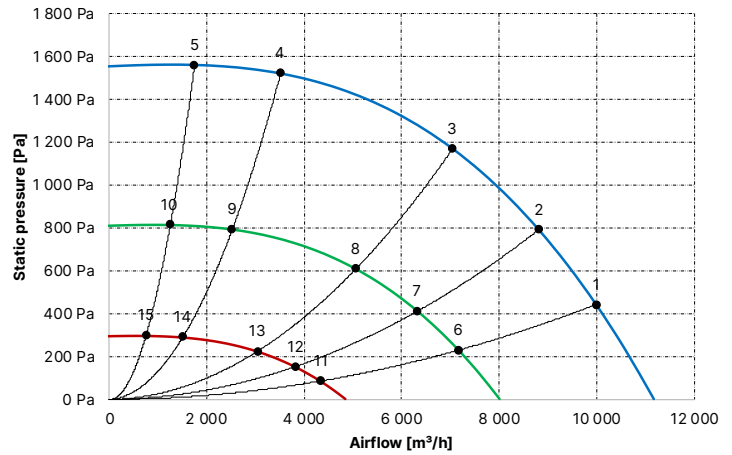

EPC = f(V)

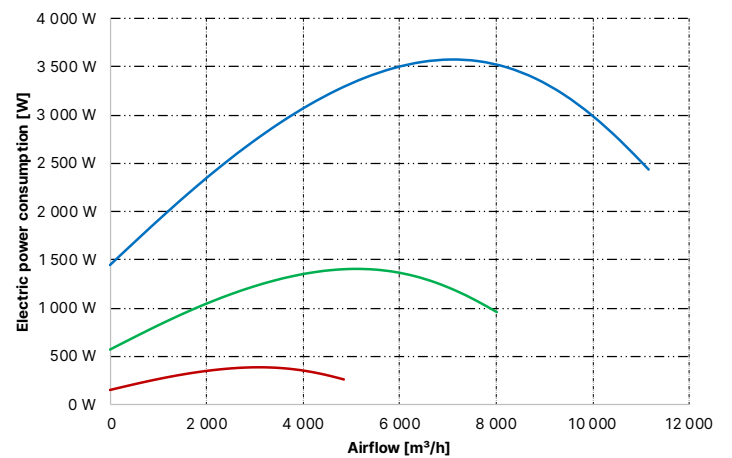

$\eta_{es} = f(V)$

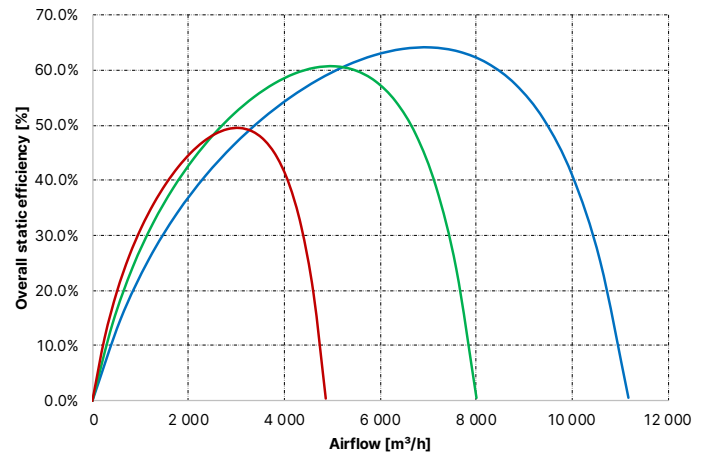

Power supply and control connections

