

Apperance

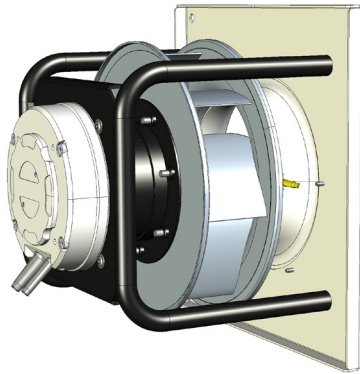

General specification

Fan Set Model	SR-FS-A-225-0.7
Rated Voltage	1×230 VAC / 50-60 Hz
Rated Current	5.7 A
Nominal Input Power	0.90 kW
Revolutions: Min / Nominal	450 ÷ 4500 RPM
CAV K-factor	47.5
Storage temperature range	-30°C to 50°C
Operating temperatures range	-25°C to 50°C
Support plate material	Galvanized steel
Support brackets material	Black painted steel
Mass	7.6 kg
Installation position	Horizontal / Vertical shaft

Motor

Type	Electronically Comutated, Brushless DC
Housing	Die-cast aluminum
Protection Degree	IP 54
Overload protection	Inbuilt thermal limit
Speed Control	0~10VDC / Modbus RTU
Bearings	Ball type, Maintenance Free, Permanently Lubricated
Bearings service life L <sub>10</sub>	63 400 (40 °C) / 31 700 (max. work. temperature)
Insulation class	F

Application

Various mechanical ventilation systems, air handling units, rooftop units, and others

Ventilation systems requiring low Specific Fan Power (SFP) together with smooth and precise airflow adjustment

Perfect solution to be combined into Fan-Array systems

Fitted for vertical and horizontal arrangement

Support to **CAV/VAV** systems (factory mounted static pressure probes on fan inlet vane + precisely determined K-factor)

Air performance according to ISO 5801, Installation Category: A, LWA according to ISO 13347.

Impeller

Fan Impeller Size	225 mm
Blade design / No of blades	Aerofoil / 7
Spinning direction	Clockwise, wiewed from air inlet
Impeller material	Aluminum
Inlet funnel material	Hot-dip galvanized steel
Balance grade	G 6,3 (ISO 1940-1) and BV-3 (ANSI S2.19-1989)

Installation Dimensions

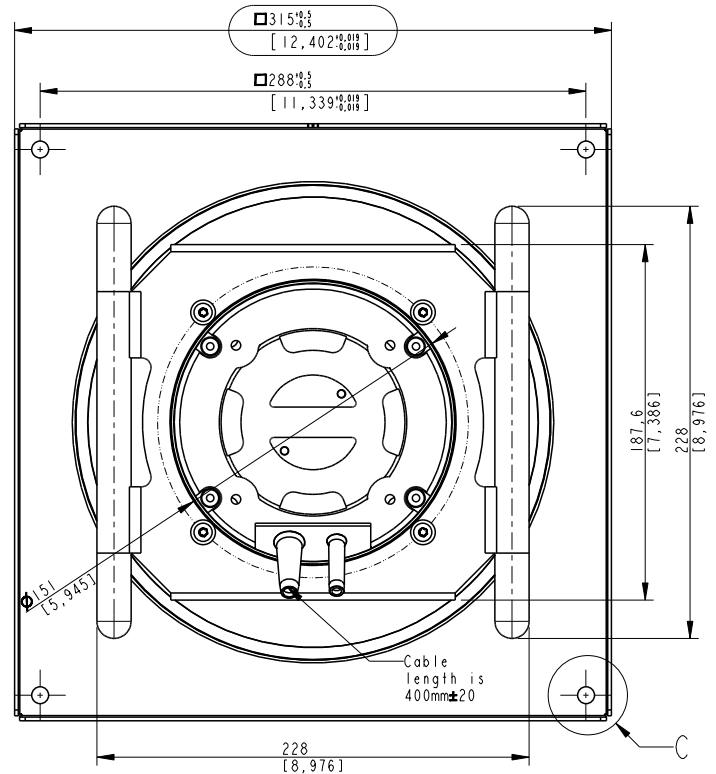
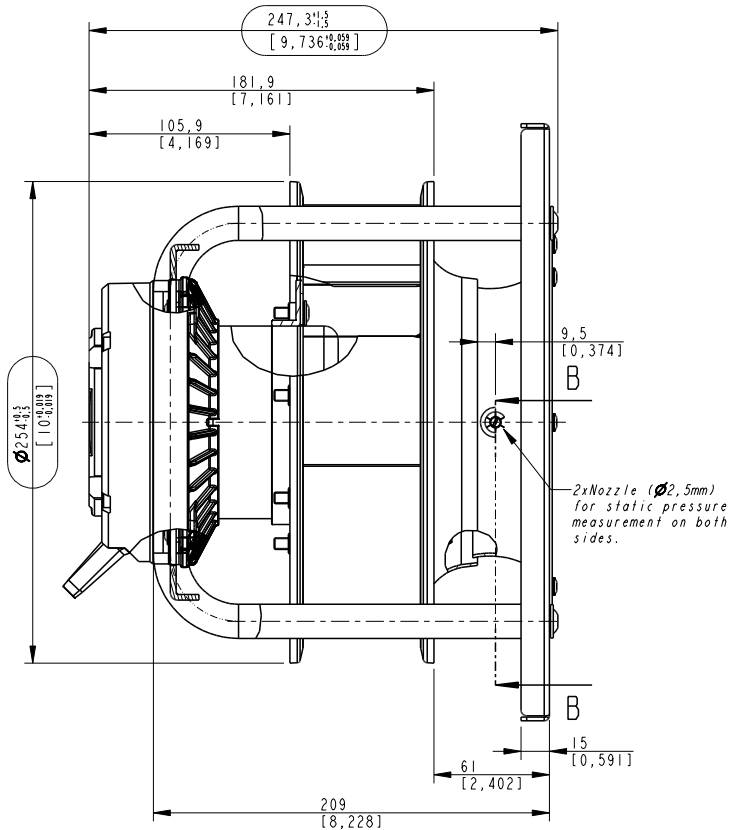

Information according to (EU) 327/2011 (ERP 2018)

<b>Commission Regulation (EU) 327/2011</b>		Requirements for fans driven by motors with an electric input power between 125 W and 500 kW.
1	Overall efficiency $\eta_{es}$	59.7%
2	Measurement category	A
3	Efficiency Category	Static
4	Efficiency grade N: Actual / Req. 2015	66.2%
5	Variable speed drive	Yes
9	Power consumption $P_{ed}$	0.83 kW
	Air flow $q_v$	1 527 m <sup>3</sup> /h
	Pressure increase pfs	1 069.4
10	Speed (rpm) n	4 500
11	Specific ratio	1.01

Compliance with Standards

ISO 5801:2017	„Fans – Performance testing using standardized airways“
ANSI/AMCA Standard 210-16	Laboratory Methods of Testing Fans for Certified Aerodynamic Performance Rating
ANSI/AMCA Standard 300-14	Reverberant Room Method for Sound Testing of Fans
AMCA Standard 205-10	Energy Efficiency Classification for Fans
ANSI/AMCA Standard 208-18	Calculation of the Fan Energy Index

AMCA Certification

Swiss Rotors Sp. z o.o. certifies that the

SR-FS-A-225-0.7 Fan Set

shown herein is licensed to bear the AMCA seal. The ratings shown are based on tests and procedures performed in accordance with AMCA Publication 211 and AMCA Publication 311 and comply with the requirements of the AMCA Certified Ratings Program.

Power rating does not include transmission losses.

Performance ratings do not include the effects of appurtenances.

Performance certified is for installation type A (Free inlet, free outlet).



AMCA Fan Efficiency Grade

Fan Efficiency Grade (FEG), AMCA 205-10	90
---	----

Measured Points

Point #	n RPM	V [m <sup>3</sup> /h]	dP [Pa]	I [A]	EPC [kW]	L <sub>pAin</sub> dB(A)	L <sub>wAin</sub> dB(A)	L <sub>wAout</sub> dB(A)	FEI
1	4 500	2 227	371	3.5	0.64	72.8	80.8	86.4	0.97
2	4 500	1 965	677	4.1	0.74	72.8	80.8	86.5	1.26
3	4 500	1 572	1 069	4.6	0.83	72.3	80.3	85.2	1.42
4	4 500	786	1 445	3.9	0.71	76.2	84.2	89.7	1.32
5	4 500	393	1 463	3.0	0.55	76.8	84.8	90.2	1.16
6	2 751	1 361	138	0.8	0.16	62.2	70.2	75.7	1.30
7	2 751	1 201	253	1.0	0.19	62.1	70.1	75.8	1.52
8	2 751	961	400	1.1	0.21	61.6	69.6	74.5	1.64
9	2 751	481	540	0.9	0.18	65.5	73.5	79.0	1.60
10	2 751	240	547	0.7	0.14	66.1	74.1	79.5	1.53
11	1 000	495	18	0.0	0.02	40.2	48.2	53.7	2.72
12	1 000	437	33	0.0	0.02	40.1	48.1	53.8	2.49
13	1 000	349	53	0.1	0.03	39.6	47.6	52.5	2.29
14	1 000	175	71	0.0	0.02	43.5	51.5	57.0	2.32
15	1 000	87	72	0.0	0.02	44.1	52.1	57.5	2.57

dP = f(V)

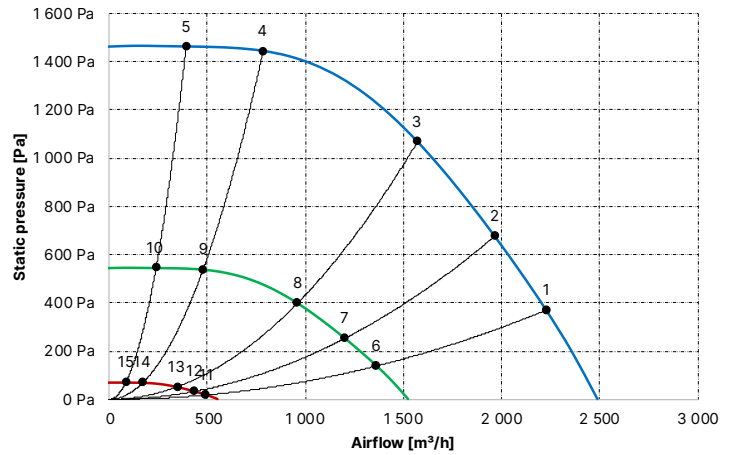

EPC = f(V)

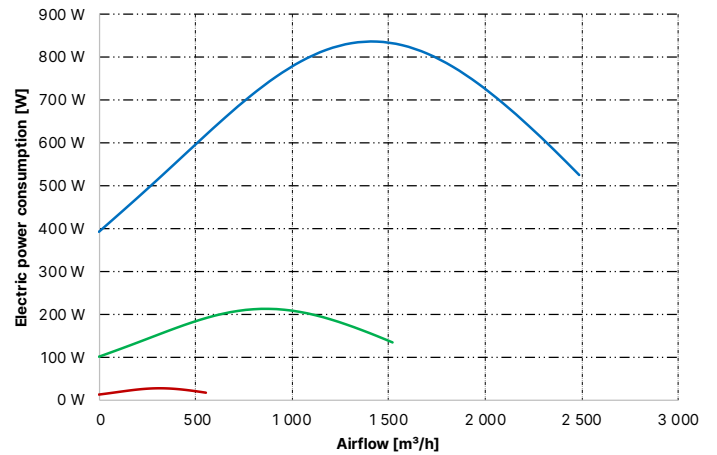

$\eta_{es}$  = f(V)

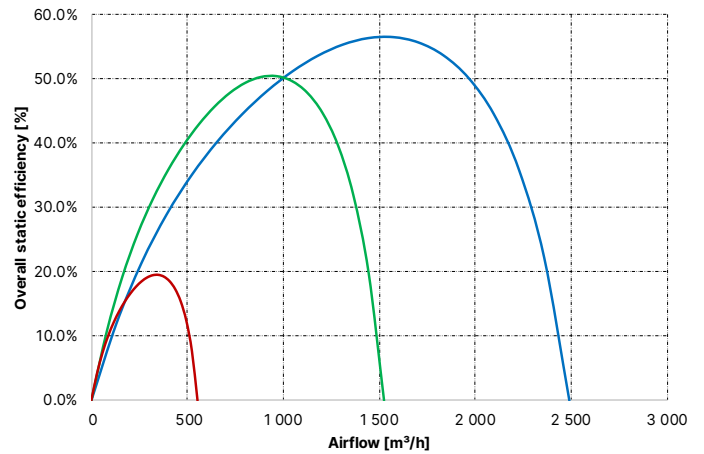

Power supply and control connections

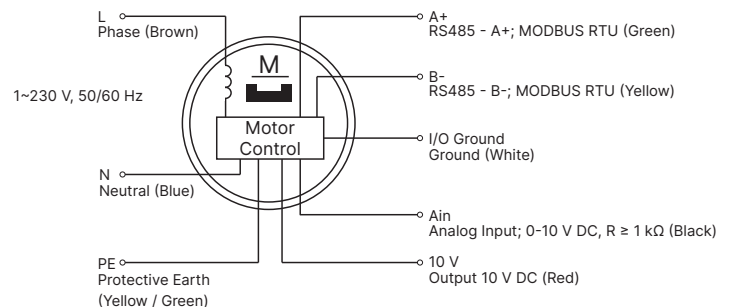

\*In the interest of continuous product improvement in the field of design, performance and reliability, Swiss Rotors Company reserves the right to make changes to this specification without prior notice.