

Apperance

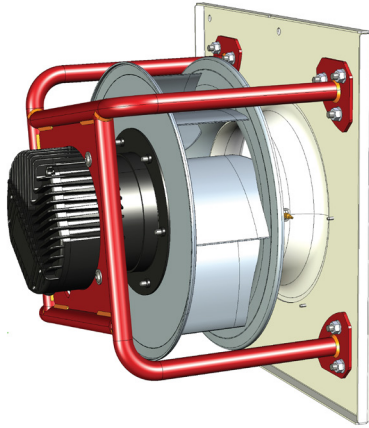

General specification

Fan Set Model	SR-FS-A-315-1.5
Rated Voltage	3×380-480 VAC / 50-60 Hz
Rated Current	3.0 A
Nominal Input Power	1.85 kW
Revolutions: Min / Nominal	325 ÷ 3250 RPM
CAV K-factor	92.1
Storage temperature range	-30°C to 50°C
Operating temperatures range	-25°C to 50°C
Support plate material	Galvanized steel
Support brackets material	Black painted steel
Mass	15.1 kg
Installation position	Horizontal / Vertical shaft

Application

Various mechanical ventilation systems, air handling units, rooftop units, and others

Ventilation systems requiring low Specific Fan Power (SFP) together with smooth and precise airflow adjustment

Perfect solution to be combined into Fan-Array systems

Fitted for vertical and horizontal arrangement

Support to CAV/VAV systems (factory mounted static pressure probes on fan inlet vane + precisely determined K-factor)

Air performance according to ISO 5801, Installation Category: A, LWA according to ISO 13347.

Motor

Type	Electronically Comuteded, Brushless DC
Efficiency Class	IE4
Housing	Die-cast aluminum
Protection Degree	IP 54
Overload protection	Inbuilt thermal limit
Speed Control	0~10VDC / Modbus RTU
Bearings	Ball type, Maintenance Free, Permanently Lubricated
Bearings service life L <sub>10</sub>	75 200 (40 °C) / 37 600 (max. work. temperature)
Insulation class	F

Impeller

Fan Impeller Size	315 mm
Blade design / No of blades	Aerofoil / 7
Spinning direction	Clockwise, viewed from air inlet
Impeller material	Aluminum
Inlet funnel material	Hot-dip galvanized steel
Balance grade	G 6,3 (ISO 1940-1) and BV-3 (ANSI S2.19-1989)

Installation Dimensions

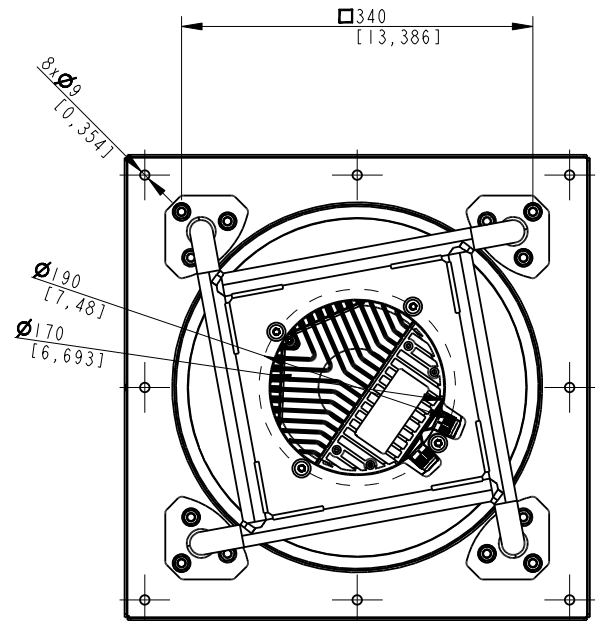
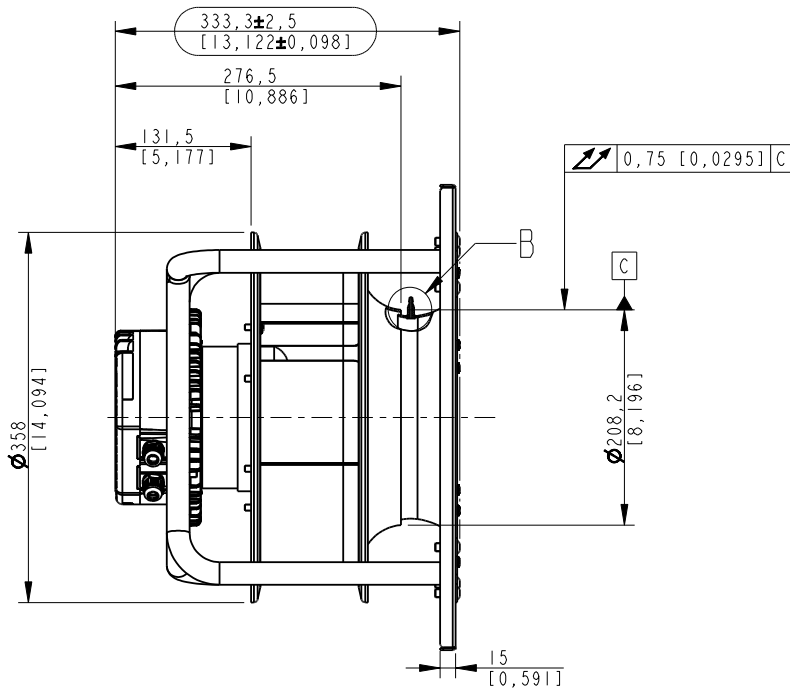

Information according to (EU) 327/2011 (ERP 2018)

<b>Commission Regulation (EU) 327/2011</b>		Requirements for fans driven by motors with an electric input power between 125 W and 500 kW.
1	Overall efficiency $\eta_{es}$	67.6%
2	Measurement category	A
3	Efficiency Category	Static
4	Efficiency grade N: Actual / Req. 2015	71.3%
5	Variable speed drive	Yes
9	Power consumption $P_{ed}$	1.69 kW
	Air flow $q_v$	3 428 m <sup>3</sup> /h
	Pressure increase pfs	1 117.8
10	Speed (rpm) n	3 250
11	Specific ratio	1.01

Compliance with Standards

ISO 5801:2017	„Fans – Performance testing using standardized airways“
ANSI/AMCA Standard 210-16	Laboratory Methods of Testing Fans for Certified Aerodynamic Performance Rating
ANSI/AMCA Standard 300-14	Reverberant Room Method for Sound Testing of Fans
AMCA Standard 205-10	Energy Efficiency Classification for Fans
ANSI/AMCA Standard 208-18	Calculation of the Fan Energy Index

AMCA Certification

Swiss Rotors Sp. z o.o. certifies that the

SR-FS-A-315-1.5 Fan Set

shown herein is licensed to bear the AMCA seal. The ratings shown are based on tests and procedures performed in accordance with AMCA Publication 211 and AMCA Publication 311 and comply with the requirements of the AMCA Certified Ratings Program.

Power rating does not include transmission losses.

Performance ratings do not include the effects of appurtenances.

Performance certified is for installation type A (Free inlet, free outlet).

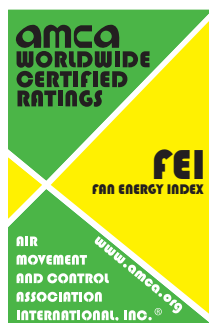

AMCA Fan Efficiency Grade

Fan Efficiency Grade (FEG), AMCA 205-10	85
---	----

Measured Points

Point #	n [RPM]	V [m <sup>3</sup> /h]	dP [Pa]	I [A]	EPC [kW]	L <sub>pAin</sub> [dB(A)]	L <sub>wAin</sub> [dB(A)]	L <sub>wAout</sub> [dB(A)]	FEI
1	3 250	4 856	424	2.0	1.38	76.3	84.3	89.8	1.01
2	3 250	4 285	724	2.2	1.56	76.0	84.0	89.6	1.26
3	3 250	3 428	1 118	2.4	1.69	75.8	83.8	88.6	1.42
4	3 250	1 714	1 457	2.0	1.39	79.1	87.1	92.7	1.21
5	3 250	857	1 473	1.5	1.06	80.0	88.0	93.3	0.95
6	2 125	3 175	180	0.6	0.41	67.1	75.1	80.5	1.23
7	2 125	2 802	307	0.6	0.46	66.8	74.8	80.4	1.41
8	2 125	2 241	473	0.7	0.50	66.6	74.6	79.4	1.53
9	2 125	1 121	617	0.6	0.41	69.9	77.9	83.5	1.34
10	2 125	560	624	0.4	0.31	70.8	78.8	84.1	1.13
11	1 000	1 494	29	0.0	0.04	50.7	58.7	64.2	3.36
12	1 000	1 318	49	0.0	0.04	50.4	58.4	64.0	3.12
13	1 000	1 055	75	0.0	0.05	50.2	58.2	63.0	2.89
14	1 000	527	98	0.0	0.04	53.5	61.5	67.1	2.57
15	1 000	264	99	0.0	0.03	54.4	62.4	67.7	2.45

dP = f(V)

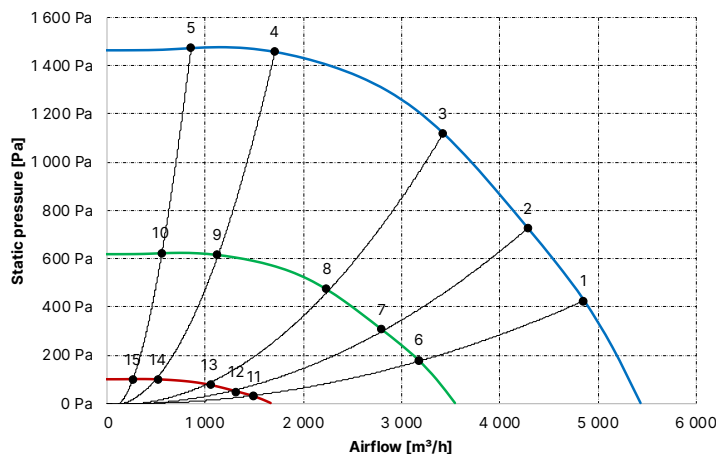

EPC = f(V)

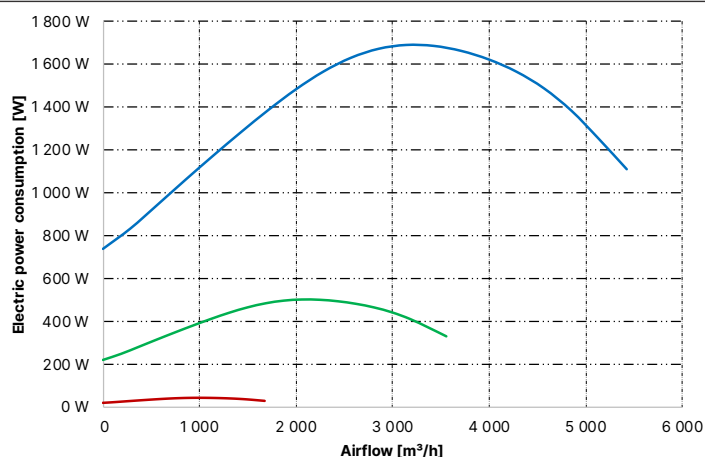

$\eta_{es} = f(V)$

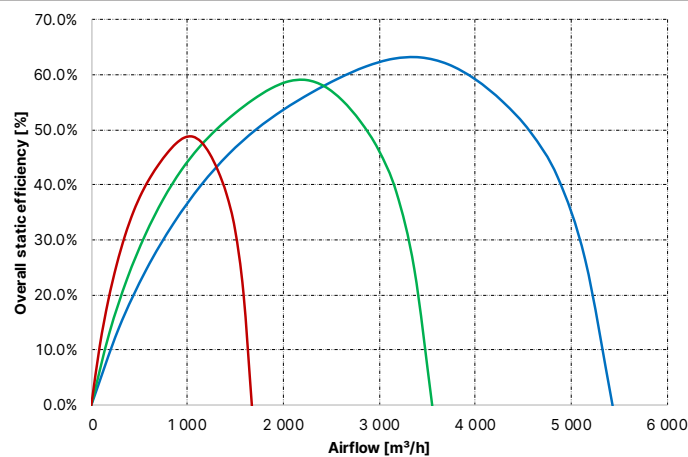

Power supply and control connections

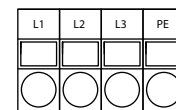
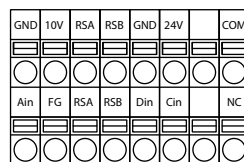

Control interface	
GND	Reference ground for control interface
Ain	Analog input for speed control 0-10V (100kOhm)
10V	Voltage output 10V DC max. 5mA
FG	Speed signal feedback output
RSA	Bus connection RS-485 - RSA - Modbus RTU
RSB	Bus connection RS-485 - RSB - Modbus RTU
GND	Reference ground for control interface
Din	Digital input
24V	Voltage output 24V DC max. 30mA
Cin	Analog input for speed control 4-20mA

Relay	
NC	Alarm relay, floating status contact
Com	Alarm relay, common connection
Power supply	
L1, L2, L3	Power supply phases - 3x380-480V AC 50/60Hz
PE	Protective Earth

\*In the interest of continuous product improvement in the field of design, performance and reliability, Swiss Rotors Company reserves the right to make changes to this specification without prior notice.